

AERA/AERSCO
AERA Technical Services Department
500 Coventry Lane, Suite 180 Crystal Lake IL 60014
Phone 888/324-2372 Fax 888/329-2372

TECHNICAL BULLETIN		
	October 2008 TB 2511	

Revised Intake Manifold Mounting Hardware For
2000-2008 Mack MP7 & MP8 Diesel Engines

The AERA Technical Committee offers the following information regarding new intake manifold mounting hardware for 2000-2008 Mack MP7 & MP8 diesel engines.

During September of 2008 the replacement intake manifold mounting hardware for Mack MP7 and MP8 engines has been developed and improved from the original hardware. These components are available through Mack Parts Systems. The new hardware consists of 12 flange screws, Part #20976035, and spacers Part #948871.

Should loose or missing intake manifold mounting screws be encountered, or anytime the intake manifold has been removed, the new flange screws and spacers must be used to replace all the existing manifold mounting hardware.

Figure 1. Intake Manifold Mounting Hardware

Key	Quantity	Part Number	Description
1	12	20976035	Flange screw, intake manifold mounting
2	1	2948871	Spacer, intake manifold mounting

Mack Trucks, Inc. engages in a continuous program of testing and evaluating to provide the best possible product. Mack Trucks, Inc., however, is not committed to, or liable for updating existing chassis.

The AERA Technical Committee

This information is provided from the best available sources. However, AERA does not assume responsibility for data accuracy or consequences of its application. Members and others are not authorized to reproduce or distribute this material in any form, or issue it to their branches, divisions, or subsidiaries, etc. at a different location, without written permission.
© Copyright AERA 2006



Reference:	
-------------------	--

TECHNICAL BULLETIN



October 2008

TB 2511

Bulletin Diagram: FIGURE 1. INTAKE MANIFOLD MOUNTING HARDWARE - ENGINE ASSEMBLY

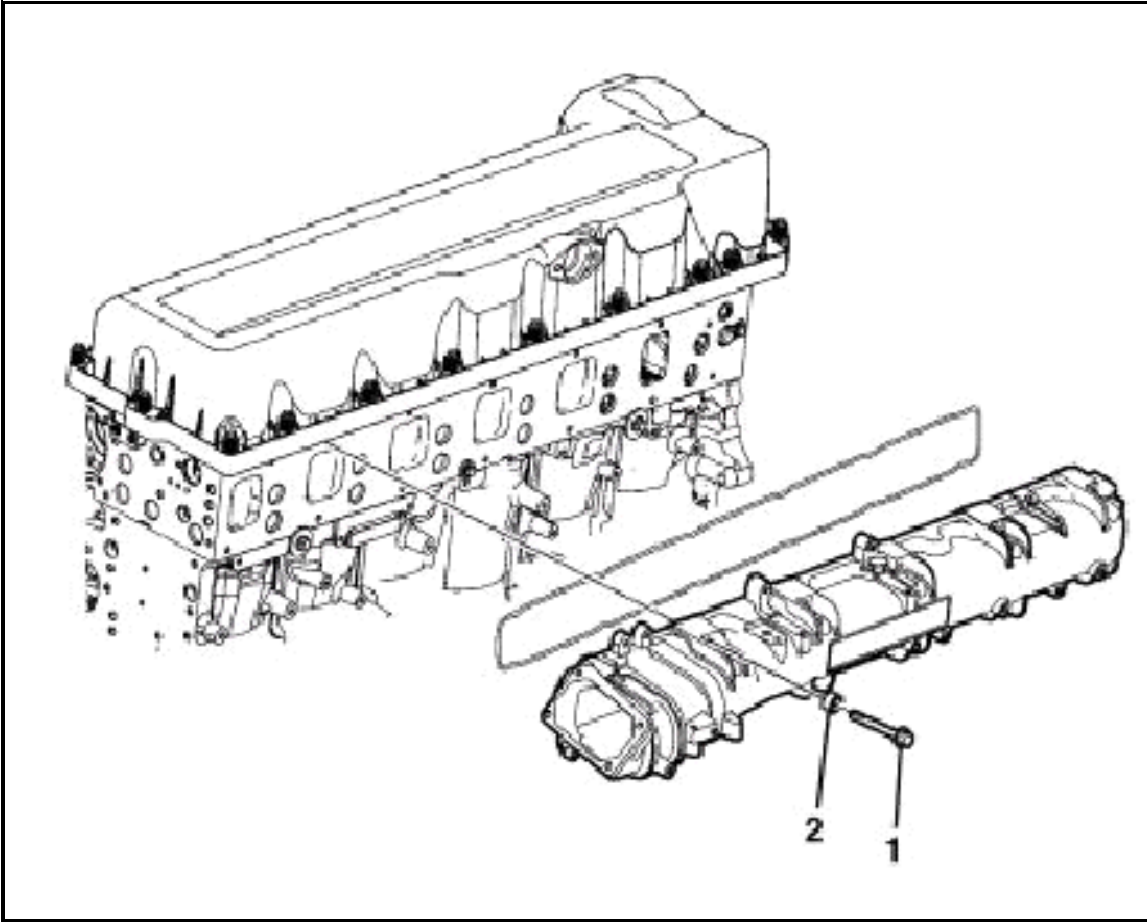

This information is provided from the best available sources. However, AERA does not assume responsibility for data accuracy or consequences of its application. Members and others are not authorized to reproduce or distribute this material in any form, or issue it to their branches, divisions, or subsidiaries, etc. at a different location, without written permission.
© Copyright AERA 2006



Reference: _____